

SOT23 PNP SILICON PLANAR SWITCHING TRANSISTORS

ISSUE 4 – MARCH 2000

FMMT3905 FMMT3906

PARTMARKING DETAILS - FMMT3905 - 2W
FMMT3906 - 2A

COMPLEMENTARY TYPES - FMMT3905 - FMMT3903
FMMT3906 - FMMT3904

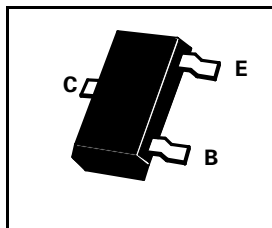

ABSOLUTE MAXIMUM RATINGS.

PARAMETER	SYMBOL	VALUE	UNIT
Collector-Base Voltage	V_{CBO}	-40	V
Collector-Emitter Voltage	V_{CEO}	-40	V
Emitter-Base Voltage	V_{EBO}	-5	V
Continuous Collector Current	I_C	-200	mA
Power Dissipation at $T_{amb}=25^{\circ}C$	P_{tot}	330	mW
Operating and Storage Temperature Range	$T_j; T_{stg}$	-55 to +150	$^{\circ}C$

ELECTRICAL CHARACTERISTICS (at $T_{amb} = 25^{\circ}C$ unless otherwise stated).

PARAMETER	SYMBOL	FMMT3905		FMMT3906.		UNIT	CONDITIONS.
		MIN	MAX	MIN	MAX		
Breakdown Voltages	$V_{(BR)CBO}$	-40		-40		V	$I_C=-10\mu A, I_E=0$
	$V_{(BR)CEO}$	-40		-40		V	$I_C=-1mA, I_B=0^*$
	$V_{(BR)EBO}$	-5		-5		V	$I_E=-10\mu A, I_C=0$
Cut-Off Currents	I_{CEX}		-50		-50	nA	$V_{CE}=-30V, V_{BE(off)}=-3V$
	I_{BEX}		-50		-50	nA	$V_{CE}=-30V, V_{EB(off)}=-3V$
Static Forward Current Transfer Ratio	h_{FE}	30 40 50 30 15	150	60 80 100 60 30	300		$I_C=-0.1mA, V_{CE}=-1V^*$ $I_C=-1mA, V_{CE}=-1V^*$ $I_C=-10mA, V_{CE}=-1V^*$ $I_C=-50mA, V_{CE}=-1V^*$ $I_C=-100mA, V_{CE}=-1V^*$
Saturation Voltages	$V_{CE(sat)}$		-0.25 -0.4		0.25 0.4	V	$I_C=-10mA, I_B=-1mA^*$ $I_C=-50mA, I_B=-5mA^*$
	$V_{BE(sat)}$	-0.65	-0.85 -0.95	-0.65	-0.85 -0.95	V	$I_C=-10mA, I_B=-1mA^*$ $I_C=-50mA, I_B=-5mA^*$
Transition Frequency	f_T	200		250		MHz	$I_C=-10mA, V_{CE}=-20V$ $f=100MHz$
Output Capacitance	C_{obo}		4.5		4.5	pF	$V_{CB}=-5V, I_E=0, f=100KHz$
Input Capacitance	C_{ibo}		10		10	pF	$V_{BE}=0.5V, I_C=0, f=100KHz$
Noise Figure	N		5		4	dB	$I_C=-200mA, V_{CE}=-5V$ $R_g=2k\Omega, f=30Hz$ to 15kHz at -3dB points

*Measured under pulsed conditions. Pulse width=200 μs . Duty cycle =1%

FMMT3905

FMMT3906

SWITCHING CHARACTERISTICS (at $T_{amb}=25\text{ }^{\circ}\text{C}$ unless otherwise stated)

PARAMETER	SYMBOL	FMMT3905		FMMT3906		UNIT	CONDITIONS
		MIN	MAX	MIN	MAX		
Delay Time	t_d		35		35	ns	$V_{CC}=-3\text{V}$, $V_{BE(off)}=-0.5\text{V}$ $I_C=-10\text{mA}$, $I_{B1}=-1\text{mA}$ (See Fig.1)
Rise Time	t_r		35		35	ns	
Storage Time	t_s		200		225	ns	$V_{CC}=-3\text{V}$, $I_C=-10\text{mA}$ $I_{B1}=-I_{B2}=-1\text{mA}$ (See Fig.2)
Fall Time	t_f		60		75	ns	

Delay and Rise Time

Equivalent Test Circuit

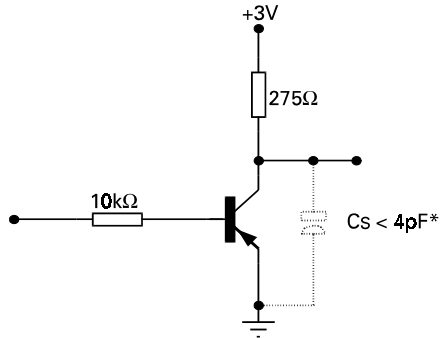
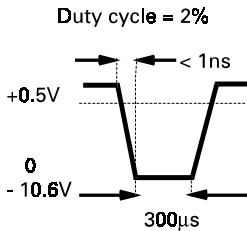

Storage and Fall Time

Equivalent Test Circuit

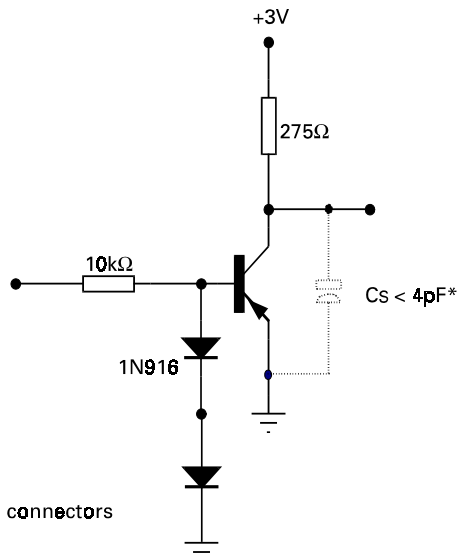
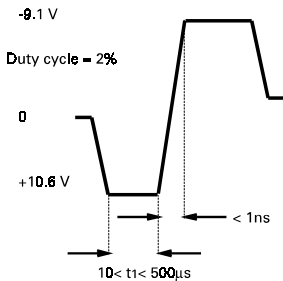

* Total shunt capacitance of test jig and connectors